



35 6124VAC DSI

24 VAC Microprocessor-Based Direct Spark Ignition

ELECTRONICS

ACOUSTIC

WEIGHT

OVERLOADING
SAFETY SYSTEMS

VALVES

TEMPERATURE

DETECT
A FIRE®

FLOW

DENSITY

INTERFACE

PRESSURE

LEVEL

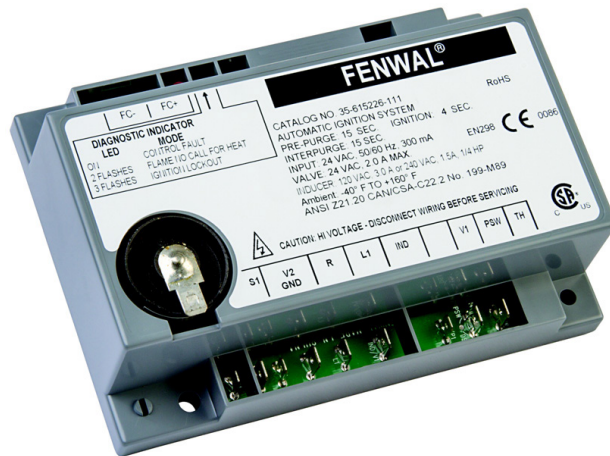

Features

- Safe start with DETECT-A-FLAME® flame sensing technology
- Custom pre-purge and inter-purge timings*
- Inducer blower control and airflow switch monitoring
- Single or three trials for ignition
- System diagnostic LED
- Flame current test points
- Local or remote flame sensing
- Automatic reset**
- Alarm output (normally closed contact)

Application

- Gas furnaces
- Boilers
- Commercial cooking
- Water heaters
- Other gas-fired appliances

Description

The 35-61 is a 24 VAC direct spark ignition (DSI) control designed for use in all types of gas-fired appliances. The control uses a microprocessor to continually and safely monitor, analyze and control the proper operation of a gas burner and inducer blower. On-board diagnostics with LED output makes troubleshooting easy and ensures safe and efficient operation.

Export Information (USA)

Jurisdiction: EAR
ECCN: EAR99

Agency Certifications

 Recognized under the UL component program, UL 372. Software certified to ANSI/UL 1998. UL File MH8817

 Design Certified to ANSI Z21.20, CAN/CSA C22.2 No. 199-M89

 CE Approved to EN 298-2012

 Code Compliant to:
AS 4625 - 2008
AS 4622 - 2004

* Pre-purge time cannot exceed inter-purge time on CE Approved models.
** Automatic reset is not allowed for CE Approved models.
*** EMC emission requirements shall be verified after incorporation of the burner control system into the end use appliance.

Specifications

Input Power	Control: 18-30 VAC 50/60Hz (Class 2 transformer)
Line Voltage	120 or 240 VAC 50/60 Hz (L1 & IND contacts only)
Input Current	300 mA @24 VAC with gas valve and inducer blower relays energized (control only)
Gas Valve	2.0A max @ 24 VAC
Inducer Blower	3.0 FLA @ 120 VAC (6.0 LRA) 1.5 FLA @ 240 VAC (3.0 LRA) 1/4 H.P. Motor
Operating Temperature	-40°F to +176°F (-40°C to +80°C)
Storage Temperature	-40°F to +185°F (-40°C to +85°C)
Flame Sensitivity	0.7 µA minimum
Flame Failure Response	0.8 seconds maximum
Flame Detector Self-check Rate	Once per second minimum
Gas Types	Natural, LP, or manufactured
Spark Rate:	
Remote	50/60 sparks/sec
Local	25/30 sparks/sec
Size (LxWxH) with enclosure	5.69 x 3.94 x 1.87 inches (14.45 x 10.01 x 4.75 cm)
Moisture Resistance	Conformal coated to operate noncondensing to 95% R.H. Module should not be exposed to water
Ingress Protection	Not rated, protection provided by appliance in which it is installed
Tries for Ignition	One or three try versions available
Trial for Ignition Periods	4, 7, 10, 15 seconds available
Pre-purge and Inter-purge Timings	0, 15 or 30 seconds available
Post-purge Time	0, 30 or 60 seconds available

Sequence of operation / flame recovery / safety lockout

Power Up / Stand By

Upon applying power to 24VAC(R), the control will reset, perform a self-check routine, flash the diagnostic LED and enter the thermostat scan state.

Start Up - Heat Mode

When a call for heat is received from the thermostat supplying 24 VAC to TH/W, the control will check the pressure switch for normally open contacts. The inducer blower is then energized.

Once the pressure switch contacts close, a pre-purge delay begins. Following the pre-purge period, the gas valve is energized and sparking commences for the Trial for Ignition (TFI) period.

When flame is detected during the TFI, the sparking process is terminated and the gas valve and inducer blower remain energized. The thermostat, pressure switch and burner flame are constantly monitored to assure proper system operation.

When the thermostat is satisfied and the demand for heat terminates, the gas valve is immediately de-energized. The control verifies the loss of flame signal and initiates an optional post-purge period before de-energizing the inducer blower.

Failure to Light - Lockout

Single trial model

Should the burner fail to light, or a flame is not detected during the TFI period, the gas valve will de-energize and the control will go into lockout. The inducer blower will turn off following the optional post-purge period. The LED will indicate the fault code for ignition lockout.

Multi trial model

Should the burner fail to light or the flame is not detected during the TFI period, the gas valve will de-energize. The control will then go through an inter-purge delay before an additional ignition attempt. The control attempts two additional ignition trials before de-energizing the gas valve and entering lockout.

The inducer blower will turn off following the optional postpurge period. The LED will indicate the fault code for ignition lockout.

Flame failure - re-ignition mode

If the established flame signal is lost while the burner is operating, the control will respond within 0.8 seconds by immediately energizing the H.V. spark for the TFI period in an attempt to relight the flame. If the burner does not light within the TFI, the gas valve will immediately de-energize and single try models will enter lockout. On multi-try models, a new TFI sequence will begin after an inter-purge delay. Multi-try models perform two additional attempts to light the burner. If the burner relights, normal operation resumes. If the burner does not relight, the control will enter lockout and the inducer blower will turn off following the optional post-purge period.

Flame failure-recycle mode

With the "Recycle After Loss of Flame" option, upon loss of flame, the gas valve is de-energized and the control proceeds to inter-purge before attempting to relight the flame. Multi-try models permit three tries for ignition including inter-purges. If the burner relights, normal operation resumes. If the burner does not relight, the control will enter lockout and the inducer blower will turn off following the optional post-purge period.

Lockout Recovery

Recovery from lockout requires a manual reset by either resetting the thermostat, or removing 24 VAC for a period of 5 seconds. On models with automatic reset, if the thermostat is still calling for heat after one hour, then the control will automatically reset and attempt to ignite the burner.

Combustion Airflow Fault

Combustion airflow is continually monitored during an ignition sequence by the pressure switch (PSW). If during the initial call for heat, the switch contacts are in the closed position for 30 seconds, without the inducer blower being energized, the LED will indicate an airflow fault and remain in this mode with the inducer blower off. If the pressure switch contacts later open while there is still a call for heat, the control will begin the prepurge period followed by a normal ignition sequence.

If the pressure switch remains open for more than 30 seconds after the inducer blower output (L1 & IND) is energized, the LED will indicate an airflow fault and the control will remain in this mode with the inducer blower on, waiting for the pressure switch to close. When proper airflow is detected at the pressure switch input (PSW) the control will begin the pre-purge period followed by a normal ignition sequence.

If the airflow signal is lost while the burner is firing, the control will immediately de-energize the gas valve and the inducer blower will remain on. If the call for heat remains, the control will wait until proper airflow returns. If proper airflow is not detected after 30 seconds, the LED will indicate the fault code for an airflow fault. If proper airflow is detected at any time, a normal ignition sequence will begin with the pre-purge period.

MOUNTING AND WIRING

The Series 35-61 control is not position sensitive and can be mounted vertically or horizontally. The case may be mounted on any surface with #6 sheet metal screws. The control also supports direct mounting to a standard NEC 4-in. junction box.

CAUTION

All wiring must be performed in accordance with both local and national electrical codes.

CAUTION

Label all wires prior to disconnection when servicing controls. Wiring errors may cause improper and dangerous operation. A functional checkout of a replacement control should always be performed.

WARNING

This product uses voltages of shock hazard potential. Wiring and initial operation must be performed by a qualified service technician.

WARNING

Operation outside specifications could result in failure of the Fenwal product and other equipment with potential for injury to people and property.

High Voltage and Remote Sense Cable Requirements

The HV Ignition Cable must meet a voltage rating of 25 KV and an insulation rating of 200 °C. Recommend length of 3ft (.9m) or less. Consult factory for longer lengths.

Remote flame sense cable must meet a voltage rating of 250V and an insulation rating of 200 °C. Recommended length of 10ft (3m) or less. Consult Factory for longer lengths.

Terminal designations

Terminal	Description	Quick Connect (inch)
TH/W	Thermostat Input	1/4"
PSW	Pressure Switch Input	1/4"
V1	Valve Power (output)	3/16"
NC	Alarm (normally closed contact)	1/4"
IND	Inducer Blower (output)	1/4"
L1	120/240 VAC Input (hot)	1/4"
24VAC/R	24 VAC Supply Power	1/4"
V2	Valve Ground	3/16"
GND	System Ground	3/16"
S1	Remote Flame Sensor	3/16"
H.V.	High Voltage Output	Varies by model
FC+, FC-	Flame Current Test Points	Varies by model

Note: NC terminal is not available on CE Approved models.

Wiring Diagrams - 35-61

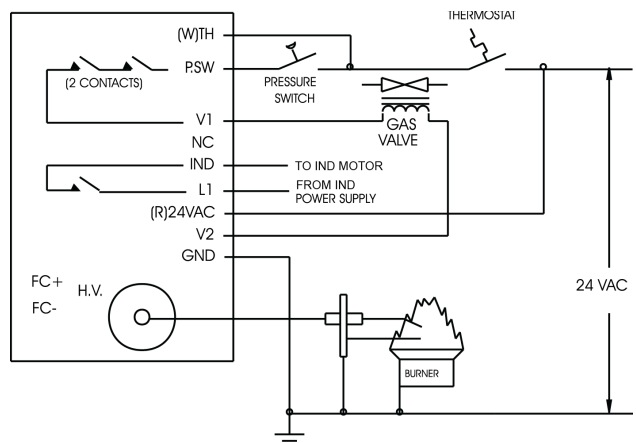

Figure 1. Local Sense

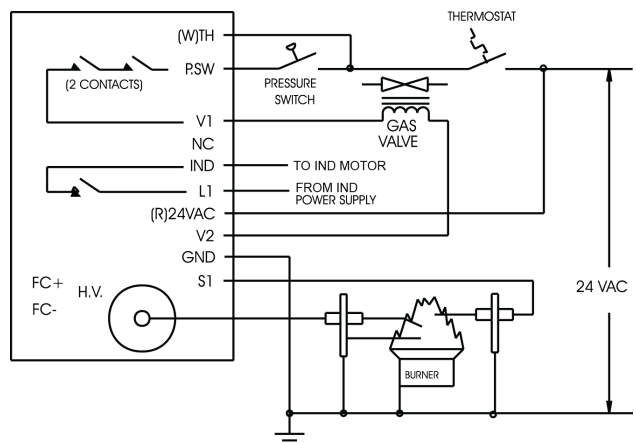

Figure 2. Remote Sense

MOUNTING AND WIRING

Troubleshooting Guide

Symptom	Recommended Actions
1. Control does not start	A. Miswired B. 24 VAC transformer fault C. Fuse circuit breaker fault D. Faulty control, check LED for fault codes
2. Thermostat on - no spark	A. Miswired B. Faulty thermostat, no voltage at thermostat terminal TH/W C. Faulty control, check LED for fault codes
3. Blower on - no TFI after purge delay	A. Miswired B. Flame fault C. Airflow fault (check voltage at PSW) D. Faulty control (check voltage between L1 & IND)
4. Valve on - no spark during TFI	A. Shorted electrode - establish 1/8-inch gap B. Check high voltage cable C. Miswired
5. Spark on - valve off	A. Valve coil open B. Valve wire disconnected C. Faulty control, check voltage at gas valve terminal V1
6. Flame okay during TFI - no flame sense after TFI	A. Check electrode position B. Check high voltage wire C. Poor ground at burner D. Poor flame, check flame current

Fault Conditions

LED Indication	Fault Mode
Steady On	Internal Control Failure
1 Flash	Airflow Fault
2 Flashes	Flame without call for heat
3 Flashes	Ignition Lockout

Note:

During a fault condition, the LED will flash on for 1/4 second and off for 1/4 second as needed to indicate the fault code. The code will repeat every 3 seconds. Removing power from the control will clear the fault code.

Internal Control Failure

If the control detects a software or hardware error, all outputs are turned off and the LED displays a Steady On condition. If this condition persists after an attempt to restart, then the control must be replaced.

Flame Fault

If at any time the gas valve fails to completely close and maintains a flame, the flame sense circuit will detect it and energize the inducer blower. Should the valve later close completely removing the flame signal, the inducer blower will be turned off following the optional post purge period.

Proper Electrode Location

Proper location of electrode assembly is important for optimum system performance. The electrode assembly should be located so that the tips are inside the flame envelope and about 1/2-inch (1.2 cm) above the base of the flame as shown:

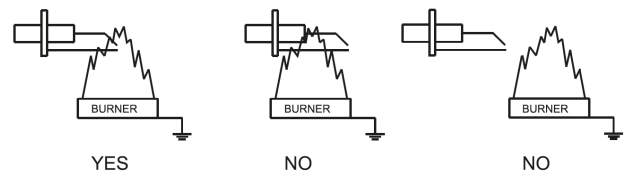

Notes:

- Ceramic insulators must not be in or close to the flame.
- Electrode assemblies must not be adjusted or disassembled. Electrodes are NOT field adjustable.
- Electrodes should have a gap spacing of 0.125 ± 0.031 in (3.12 ± 0.81 mm), unless otherwise specified by the appliance manufacturer. If spacing is not correct, the assembly must be replaced.
- Exceeding temperature limits can cause nuisance lockouts and premature electrode failure.
- Electrodes must be located where they are not exposed during normal operation.

Flame Current Measurement

Flame current is the current that passes through the flame from sensor to ground. To measure flame current, connect a True RMS or analog DC microammeter to the FC+ and FC- terminals. Readings should be 1.0 μ A DC or higher. If the meter reads negative or below "0" on scale, meter leads are reversed. Reconnect leads with proper polarity. Alternately, a Digital Voltmeter may be used to measure DC voltage between FC+ and FC- terminals. Each micro-amp of flame current produces 1.0 VDC. For example, 2.6 VDC equates to 2.6 μ A.

A good burner ground that matches the control ground is critical for reliable flame sensing.

DIMENSIONS

Quick Connect Models

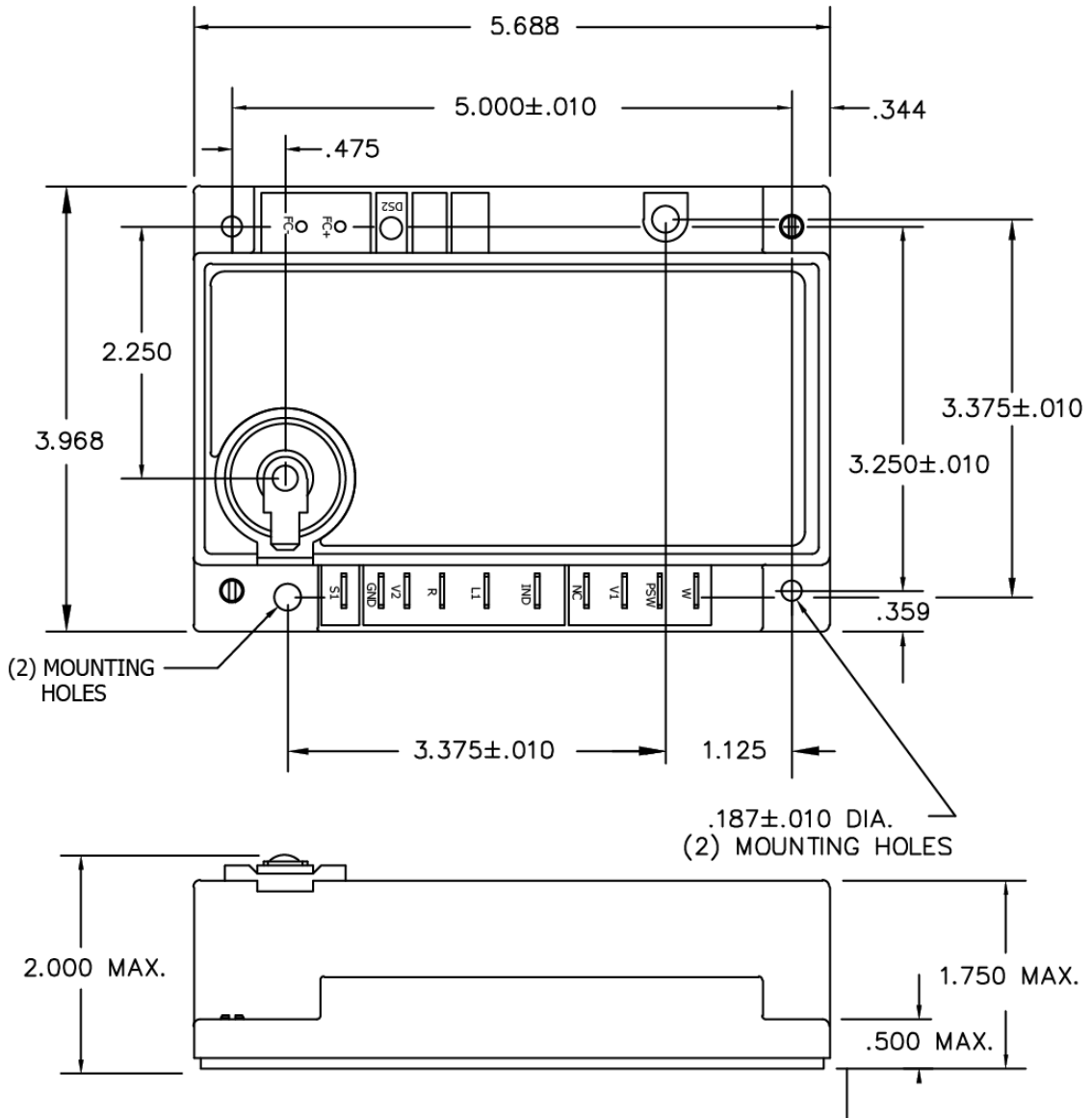

Figure 3. Standard Enclosure

Note: All dimensions are in inches.

Part number configuration

SERIES 35-615 X X X - X X X

Product Designation

- 2 = Standard CE Approved Model*
- 3 = Special CE Approved Model*
- 5 = Standard
- 8 = Aftermarket Kit
- 9 = Special Configuration

A 3, 8 or 9 in this location (i.e. 35-615 901-113) indicates a special configuration.

9XX is a sequentially assigned part number and does not follow the standard part numbering configuration. Consult Fenwal for operating characteristics of this control.

*On CE Approved models, pre-purge time cannot exceed inter-purge time and automatic reset is not permitted.

Trial for Ignition

- 1 = 4 Seconds
- 3 = 7 Seconds
- 5 = 10 Seconds
- 7 = 15 Seconds

Inter-Purge

- 0 = None (Single Try Only)
- 1 = 15 Seconds
- 2 = 30 Seconds

Pre-Purge

- 0 = None
- 1 = 15 Seconds
- 2 = 30 Seconds

Tries for Ignition & Method of Flame Sense

- 0 = Single Try - Local Sense
- 1 = Single Try - Remote Sense
- 5 = Three Tries - Local Sense
- 6 = Three Tries - Remote Sense

Post-Purge

- 0 = No Post-Purge (TH/W input only)
- 1 = No Post-Purge
- 2 = 30 Second Post-Purge
- 3 = 60 Second Post-Purge

EXPORT INFORMATION (USA) Jurisdiction: EAR Classification: EAR99 This document contains technical data subject to the EAR.

This literature is provided for informational purposes only. KIDDE-FENWAL, INC. assumes no responsibility for the product's suitability for a particular application. The product must be properly applied to work correctly. If you need more information on this product, or if you have a particular problem or question, contact KIDDE-FENWAL, INC., Ashland, MA 01721.

EU declaration of conformity

We

Company Name: Kidde-Fenwal Inc.
 Postal Address: 400 Main Street
 City and Post Code: Ashland, MA 01721
 Tel: 508-881-2000

Declare that the DoC is issued under sole responsibility and belongs to the following product:

Apparatus Model(s) Series 35-40, 35-53, 35-60, 35-61, 35-63, 35-608, 35-65, 35-66, 35-9X
 Type: Fitting
 Batch Number Date code and Revision Level Assigned per production lot, (YYWW RR)

Object of the Declaration:

Series 35-40, 12/24Vdc Direct Spark Automatic Gas Ignition Controllers
 Series 35-53, 12Vdc Direct Spark Automatic Gas Ignition Controllers
 Series 35-60, 35-61, 35-63, 35-608 24Vac Direct Spark Automatic Gas Ignition
 Series 35-65 & 35-66 24Vac Hot Surface Automatic Gas Ignition Controllers
 Series 35-9X Platform Ignition Module

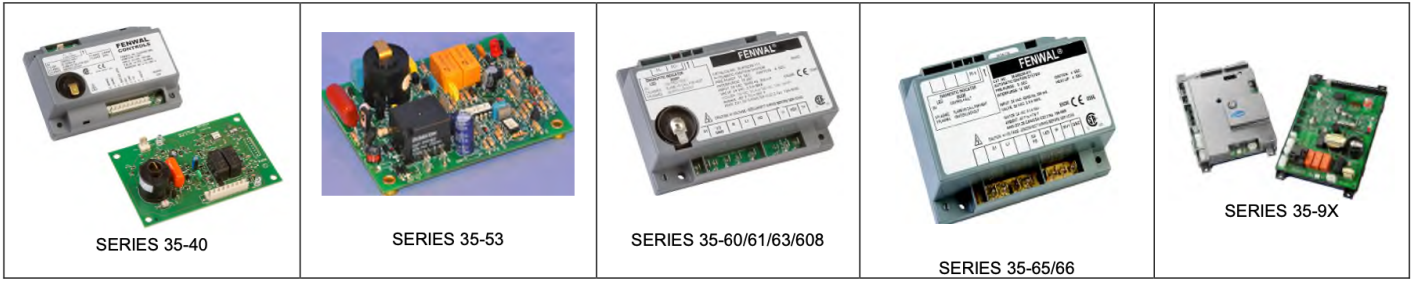

The object of the declaration described above is in conformity within the relevant union harmonization legislation:

Gas Appliance Regulation:	(EU) 2016/426	Low Voltage Directive:	2014/35/EC
EMC Directive:	2014/30/EC	Rohs	2011/65/EU

The following harmonized standards and technical specifications have been applied:

<u>EN298:2012:</u>	Automatic Burner Control systems for Burners and appliances burning gaseous or liquid fuels.
<u>EN13611:2007 A2:2011:</u>	Safety and control devices for Gas Burners and Gas burning appliances – General Requirements.

Name of Notified Body & Number: BSI Group, 0086, EU Type Examination Certification

Notified Body Certificate No.:	Series 35-40:	CE682407
	Series 35-53	CE682404
	Series 35-60/61/63/608	CE682405
	Series 35-65/66	CE682406
	Series 35-9x	CE690652

Surveillance Audit Notified Body: BSI Group

For copies of the Installation Instructions and the EU DoC, got to www.fenwalcontrols.com, - Document Library - Data sheets.

Paul Finn

Kidde-Fenwal, Inc. Ashland, MA USA
 Place of Issue:

01 Oct 2018
 Date of Issue

Paul Finn, Certification Engineer
 Name

© Kidde-Fenwal Inc. 06-237657-001 Rev AC